

12.1" LCD PANEL MOUNT MONITOR

29LP121A61PY

DATASHEET

HIGH QUALITY, LCD PANEL MOUNT MONITOR

The 29LP121A61PY Series of LCD Panel Mount monitors has been designed for the OEM / System Builder who must integrate a compact VGA colour display into limited space on a panel or bulkhead.

A strong metal chassis encloses all signal and backlight electronics. The chassis is securely fixed to a 3mm thick steel front panel. A toughened glass plate provides protection to the TFT panel. A compressible gasket around the perimeter of the panel provides IP65/ NEMA sealing of the panel/bulkhead interface. Bulkhead fixing is by means of threaded studs at the rear of the panel.

SOLUTIONS FOR PANEL MOUNT MONITORS

- > **Rugged metal construction with good stability**
The LCD monitor has been designed with solidity, being housed in a compact metal construction with a toughened glass protection screen.
- > **Optional touch screen facility**
A touch screen can be integrated into the monitor
- > **Inputs**
All monitors have RCA, 4 pin mini DIN
- > **IP65 sealing**
The front panel is sealed to IP65 rating



12.1" LCD PANEL MOUNT MONITOR

29LP121A61PY

DATASHEET

Electrical Description		Mechanical Description	
TFT Characteristics:	Type:	a-si TFT active matrix	Dimensions: Monitor: 302 x 380 x 55 mm Weight: 3kg approx
	Max Resolution:	800 x 600 pixels	Input: RCA, 4 pin mini DIN
Active Display Area:	246 x 184.5 mm	Housing: Painted aluminium	User Controls: Rear mounted
Response Time:	25ms average, typical	On Screen buttons: Brightness, Contrast, OSD	
Contrast Ratio:	350:1 typical		
Brightness:	350cd/m2 typical		
Viewing Angles (at CR>10):	160° H , 160° V		
Backlight Life:	50,000 hours typical		
No. Colours:	256k		
Video Signal:	PAL / NTSC		
Signal Sync:	Composite (CVBS) 1V p-p		
Synchronisation Range:			
Horizontal scan:	15kHz (PAL / NTSC)		
Vertical scan:	50 to 60Hz		
Power Supply:	90 - 260V AC 50/60Hz		
Power Consumption:	30W (Max)		
Environmental:	Storage Temp: -20 to 70°C Operating Temp: 0 to 50°C	Part Numbers:	
		Part number:	29LP121A61PY
		AC power pack:	20BK0234H
		Touch screen Model RS232:	29LP121AR61PY

Due to a policy of continuous product development KME reserves the right to change specifications and descriptions without prior notification. All trademarks acknowledged.

KENT MODULAR ELECTRONICS LTD
621 Maidstone Road
Rochester, Kent ME1 3QJ
T: +44 (0)1634 830123 F: +44 (0)1634 830619
E: sales@kme.co.uk W: www.kme.co.uk



12.1" LCD PANEL MOUNT MONITOR

29LP121A61PY

DATASHEET

FRONT VIEW 12.1" & 15.0"

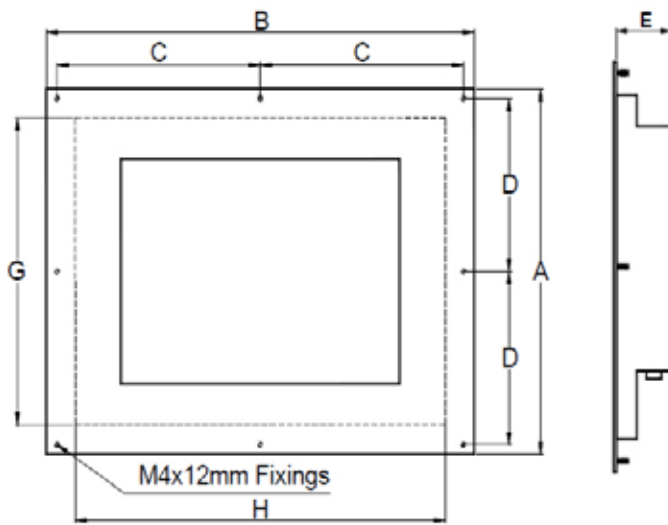

FRONT VIEW 17.0" & 19.0"

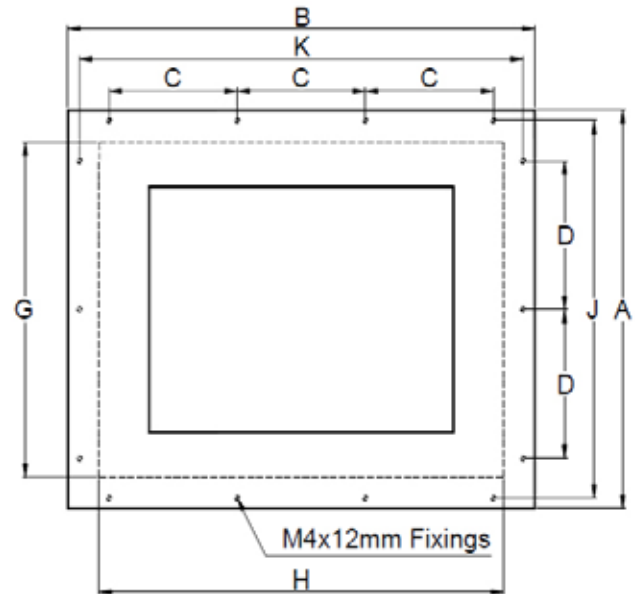

Design Notes:

1. 1. Panel Colour is normally RAL 7035.
2. 2. Panel / Rack Metal Thickness is 3mm

(Not to Scale)

Dimensions (mm)	PANEL MOUNT			
	12.1"	15.0"	17.0"	19.0"
A	302	342	400	400
B	380	428	483	483
C	180.5	206	130	130
D	143	163	150	150
E	55	60	55	60
G (Panel Hole)	264	298	334	366
H (Panel Hole)	343	390	404	436
J (Fixing Studs)	-	-	384	384
K (Fixing Studs)	-	-	467	467