

17.0" LCD PANEL MOUNT MONITOR

29LP173A61MP/5

DATASHEET

HIGH QUALITY, LCD PANEL MOUNT MONITOR

The 29LP173A61MP/5 Series of LCD Panel Mount monitors has been designed for the OEM / System Builder who must integrate a compact VGA colour display into limited space on a panel or bulkhead.

A strong metal chassis encloses all signal and backlight electronics. The chassis is securely fixed to a 3mm thick steel front panel. A toughened glass plate provides protection to the TFT panel. A compressible gasket around the perimeter of the panel provides IP65/NEMA sealing of the panel/bulkhead interface. Bulkhead fixing is by means of threaded studs at the rear of the panel.

SOLUTIONS FOR PANEL MOUNT MONITORS

- > **Rugged metal construction with good stability**
The LCD monitor has been designed with solidity, being housed in a compact metal construction with a toughened glass protection screen.
- > **Optional touch screen facility**
A touch screen can be integrated into the monitor
- > **Inputs**
All monitors have RCA and 15-D connectors
- > **IP65 sealing**
The front panel is sealed to IP65 rating



17.0" LCD PANEL MOUNT MONITOR

29LP173A61MP/5

DATASHEET

Electrical Description		Mechanical Description	
TFT Characteristics:	Type:	a-si TFT active matrix	Dimensions: Monitor: 400 x 483 x 55 mm Weight: 5kg approx
	Max Resolution:	1280 x 1024 pixels	Input: RCA, 15-D, 4 pin mini DIN
Active Display Area:	337.9 X 270.3 mm	Housing	Painted aluminium
Response Time:	25ms average, typical	User Controls:	Rear mounted
Contrast Ratio:	1000:1 typical	On Screen buttons	Brightness, Contrast, OSD
Brightness:	280cd/m ² typical		
Viewing Angles (at CR>10):	178° H , 178° V		
Backlight Life:	50,000 hours typical		
No. Colours:	16.7M		
Video Signal:	PAL / NTSC Analog 0.7Vp-p		
Signal Sync:	Composite (CVBS) 1 V p-p Separate H&V (+/ve) TTL Sync-on-Green 0.3V p-p		
Synchronisation Range:	Horizontal scan: 15kHz (PAL / NTSC) 30kHz - 60kHz Vertical scan: 50 to 60Hz		
Power Supply:	90 - 260V AC 50/60Hz		
Power Consumption:	60W (Max)		Part Numbers:
Environmental:	Storage Temp: -25 to 60°C Operating Temp: 0 to 50°C		Part number: 29LP173A61MP/5 AC power pack: 20BK0234H Touch screen Model RS232: 29LP173AR61MP/5

Due to a policy of continuous product development KME reserves the right to change specifications and descriptions without prior notification. All trademarks acknowledged.

KENT MODULAR ELECTRONICS LTD
621 Maidstone Road
Rochester, Kent ME1 3QJ
T: +44 (0)1634 830123 F: +44 (0)1634 830619
E: sales@kme.co.uk W: www.kme.co.uk



17.0" LCD PANEL MOUNT MONITOR

29LP173A61MP/5

DATASHEET

FRONT VIEW 12.1" & 15.0"

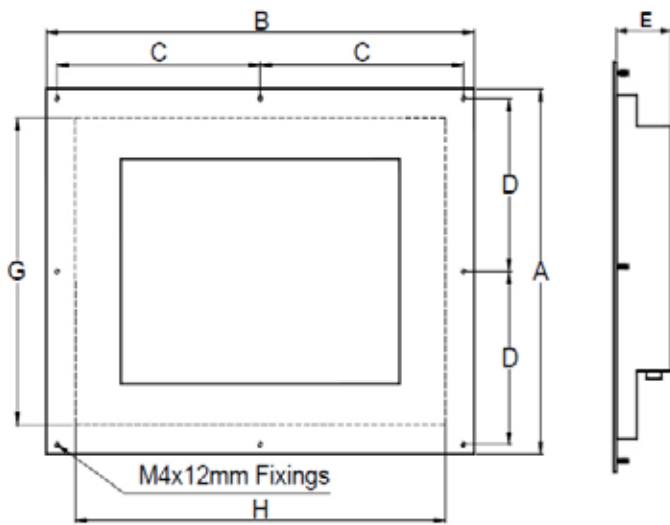

FRONT VIEW 17.0" & 19.0"

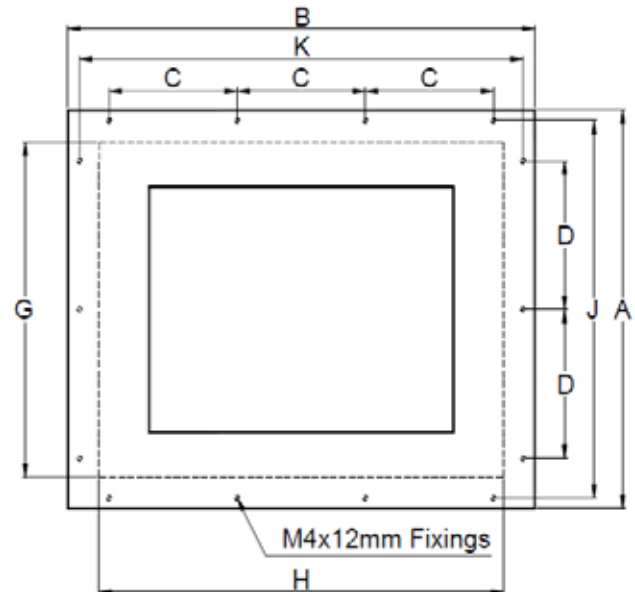

Design Notes:

1. 1. Panel Colour is normally RAL 7035.
2. 2. Panel /Rack Metal Thickness is 3mm

(Not to Scale)

Dimensions (mm)	PANEL MOUNT			
	12.1"	15.0"	17.0"	19.0"
A	302	342	400	400
B	380	428	483	483
C	180.5	206	130	130
D	143	163	150	150
E	55	60	55	60
G (Panel Hole)	264	298	334	366
H (Panel Hole)	343	390	404	436
J (Fixing Studs)	-	-	384	384
K (Fixing Studs)	-	-	467	467