

19.0" LCD PANEL MOUNT MONITOR

29LP1901A61M/2

DATASHEET

HIGH QUALITY, LCD PANEL MOUNT MONITOR

The 29LP1901A61M/2 Series of LCD Panel Mount monitors has been designed for the OEM / System Builder who must integrate a compact colour display into limited space on a panel or bulkhead.

A strong metal chassis encloses all signal and backlight electronics. The chassis is securely fixed to a 3mm thick steel front panel. A toughened glass plate provides protection to the TFT panel. A compressible gasket around the perimeter of the panel provides IP65/NEMA sealing of the panel/bulkhead interface. Bulkhead fixing is by means of threaded studs at the rear of the panel.

SOLUTIONS FOR PANEL MOUNT MONITORS

- > **Rugged metal construction with good stability**
The LCD monitor has been designed with solidity, being housed in a compact metal construction with a toughened glass protection screen.
- > **Optional touch screen facility**
A touch screen can be integrated into the monitor
- > **Inputs**
All monitors have DVI-D and 15-D connectors
- > **IP65 sealing**
The front panel is sealed to IP65 rating

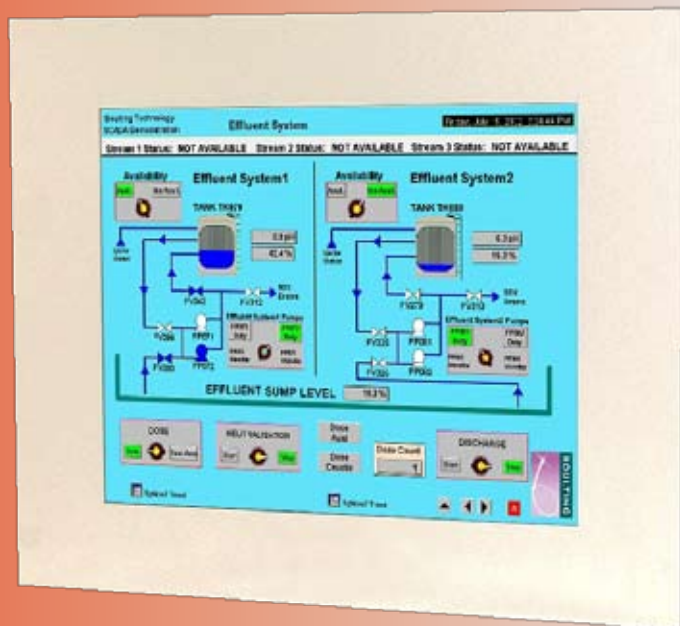

19.0" LCD PANEL MOUNT MONITOR

29LP1901A61M/2

DATASHEET

Electrical Description		Mechanical Description	
TFT Characteristics:	Type:	a-si TFT active matrix	Input:
	Max Resolution:	1280 x 1024 pixels	Housing
	Active Display Area:	376 X 301 mm	User Controls:
	Response Time:	16ms average, typical	On Screen buttons
	Contrast Ratio:	700:1 typical	
	Brightness:	250cd/m2 typical	
	Viewing Angles (at CR>10):	170° H , 170° V	
	Backlight Life:	50,000 hours typical	
	No. Colours:	16M	
	Video Signal:	Analog 0.7V p-p	
Signal Sync:	Separate H&V (+/ve) TTL		
Synchronisation Range:			
Horizontal scan:	30 - 80kHz		
Vertical scan:	50 to 80Hz		
Power Supply:	90 - 260V AC 50/60Hz		
Power Consumption:	60W (Max)		
Environmental:			Part Numbers:
Storage Temp:	-25 to 60°C		Part number:
Operating Temp:	0 to 50°C		AC power pack:
			Touch screen Model RS232:

Due to a policy of continuous product development KME reserves the right to change specifications and descriptions without prior notification. All trademarks acknowledged.

KENT MODULAR ELECTRONICS LTD
621 Maidstone Road
Rochester, Kent ME1 3QJ
T: +44 (0)1634 830123 F: +44 (0)1634 830619
E: sales@kme.co.uk W: www.kme.co.uk



19.0" LCD PANEL MOUNT MONITOR

29LP1901A61M/2

DATASHEET

FRONT VIEW 12.1" & 15.0"

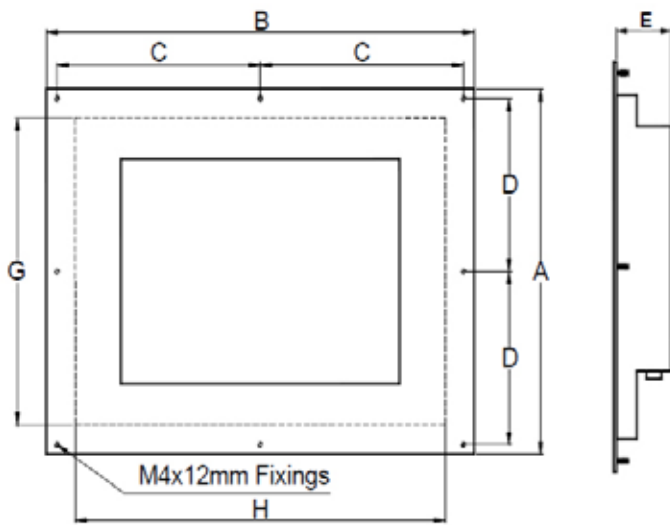

FRONT VIEW 17.0" & 19.0"

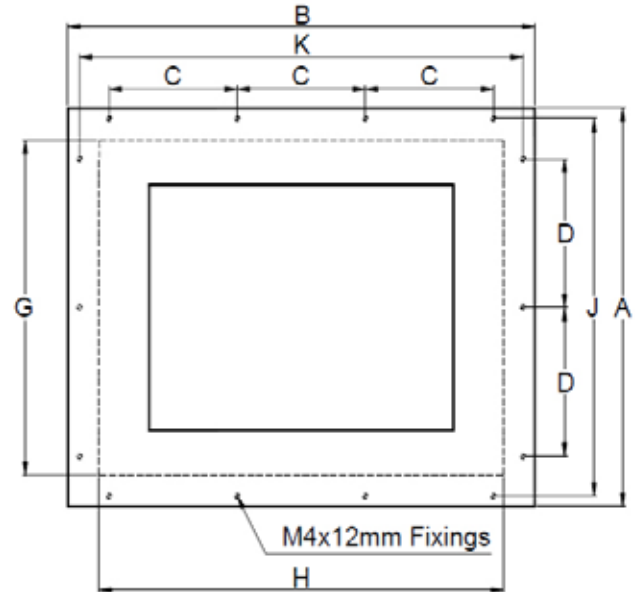

Design Notes:

1. 1. Panel Colour is normally RAL 7035.
2. 2. Panel / Rack Metal Thickness is 3mm

(Not to Scale)

Dimensions (mm)	PANEL MOUNT			
	12.1"	15.0"	17.0"	19.0"
A	302	342	400	400
B	380	428	483	483
C	180.5	206	130	130
D	143	163	150	150
E	55	60	55	60
G (Panel Hole)	264	298	334	366
H (Panel Hole)	343	390	404	436
J (Fixing Studs)	-	-	384	384
K (Fixing Studs)	-	-	467	467